



**Solid State
Micro Technology**
for Music

**SSM
2044**

4-POLE VOLTAGE CONTROLLED FILTER

DESCRIPTION

The SSM2044 is a low cost 4-pole voltage controlled filter whose design has been optimized for use as an electronic music lowpass filter. On-chip voltage control of resonance allows direct and easy interfacing with programmers and controllers. A novel filtering technique* provides extended control range, low noise and high control rejection for "pop"-free performance. The filter can also be used as a low distortion sinewave oscillator. No external ladder network is required making the device a real cost and space saver in polyphonic applications.

FEATURES

- Low Cost
- High Control Rejection (40db typical for 1000 to 1 sweep)
- $\pm 18V$ to $\pm 5V$ Supplies
- Minimum External Parts Count
- Current Output
- 90db Signal-to-Noise
- 10,000 to 1 Minimum Sweep Range
- On-Chip Resonance Control
- Differential Signal Inputs
- Stable Resonance Over Frequency Sweep

*Patent applied for.

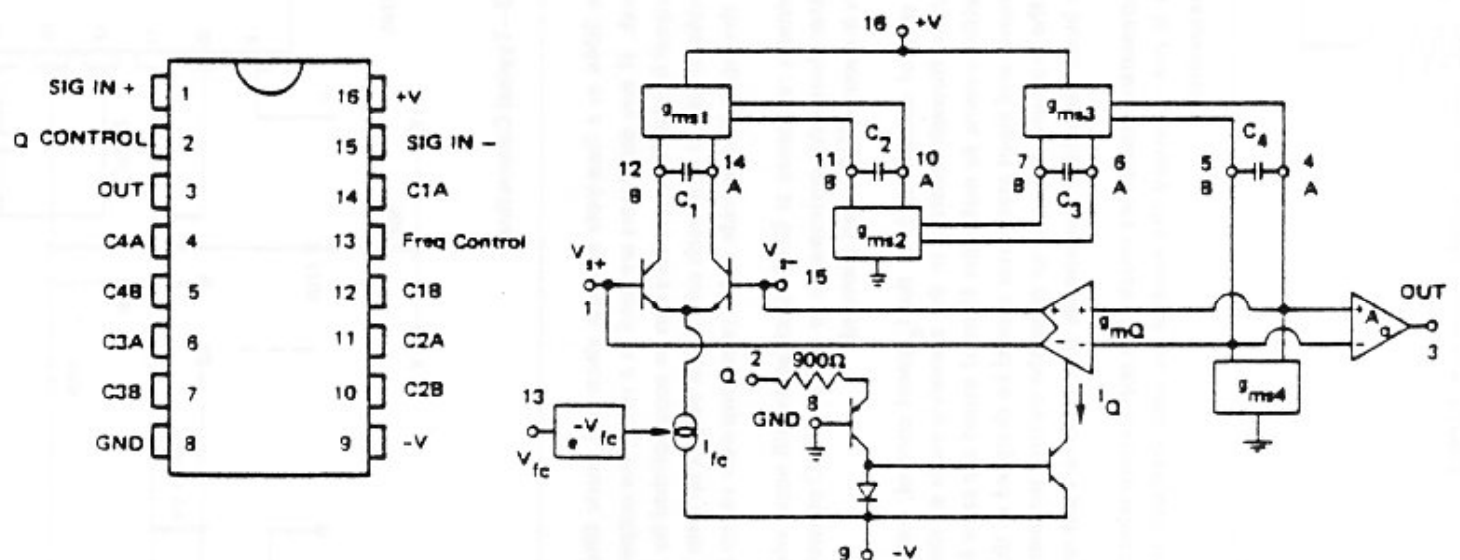

Functional Block Diagram

SPECIFICATIONS **STORAGE TEMPERATURE** **OPERATING TEMPERATURE**

PARAMETER	MIN	TYP	MAX	UNITS	CONDITIONS
Positive Supply Range	15	+15	+18	V	V _{FC} = GND V _{FC} = GND V _{FC} = GND
Negative Supply Range	-5	-15	-18	V	
Positive Supply Current	1.0	1.4	2.0	mA	
Negative Supply Current	4.5	6.2	8.0	mA	
Frequency Control Range	10,000:1	50,000:1	-		V _{FC} = V ₊ = GND -50mV ≤ V _{FC} ≤ +90mV V _{FC} = V ₋ = V _{FC} = GND Untrimmed
Frequency Control Feedthrough	-	-40db	-30db		
Output Offset I _Q /I _{OMax}	0.6	0.05	0.2		
Frequency Control Offset f/nom	-	1	1.5		
Q Control Input Impedance	6/5	900	1200	Ω	V _{OC} > 0.7V -90mV ≤ V _{IC} ≤ +90mV Untrimmed
Q Current at Oscillation	400	425	450	μA	Trimmed
Q Control Feedthrough	-	30db	-20db		
Max Available Control Current	1.25	1.7	2.2	mA	
Freq Control Input Range	-120	-	+180	mV	
Max Output Signal Current I _{OMax}	1.300	±400	±520	μA	
Signal to Noise	-	-	90db		

*FINAL SPECIFICATIONS MAY BE SUBJECT TO CHANGE.

Figure 1 below shows the amplitude vs frequency response for the 2044 at different Q or resonance settings. The solid curve is the response of the filter at minimum Q which is a gradual rolloff approaching -24db/octave at high frequencies. As Q is increased, low frequency components are suppressed and components near the cutoff frequency are emphasized. For all Q settings below oscillation the final rolloff at high frequencies is -24db/octave. At high Q settings the filter will oscillate with a pure sine wave at the cutoff frequency. This waveform can be used as a tone source if the design procedures given below are followed.

The second figure below shows Q or resonance of a four-pole lowpass filter as a function of feedback or Q control current. The function changes very slowly with control current at the low end but increases very rapidly as oscillation is approached. In general, this type of filter causes a problem when designing a Q panel control that has the right feel. The optimum control pot would have the reciprocal of this response, a requirement approximated by an audio pot connected in reverse of its normal configuration: a "reverse audio" pot. To obtain maximum resolution from the pot, a resistor that is one-third of its value can be connected in series to ground. This will discard the lower 25% of the Q response curve where almost nothing happens. Figure 4.

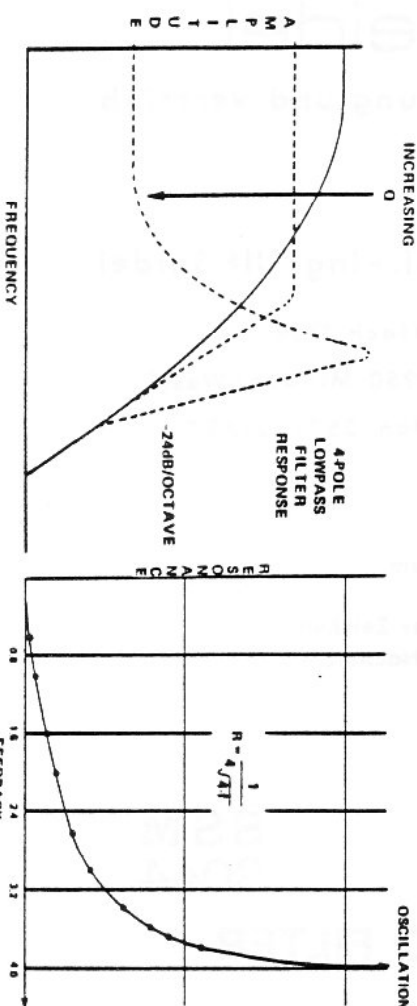

Figure 1

Figure 2

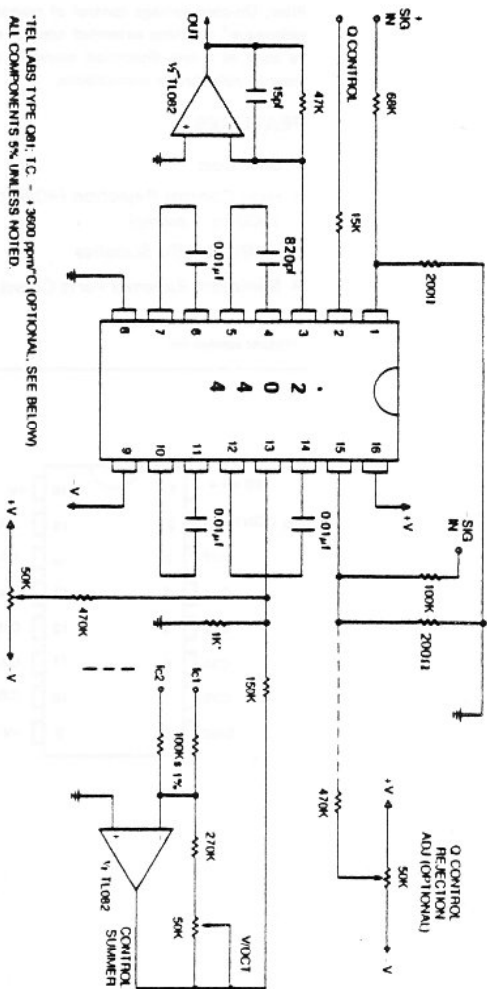

Figure 3—Typical Connection

The figure above shows the typical connection of the 2044 as a four-pole lowpass electronic music filter. The differential signal inputs will accept any signal(s) up to ±18V peak-to-peak. If two oscillators are used in a voice, the output of the second should go to the opposite filter input from the first with a 3db signal level difference. This can be accomplished by scaling the input attenuators as shown, thus preventing cancellation as the oscillators phase with each other. The output op amp is required to convert the output current to a buffered voltage. The capacitors at the input pins provide stable resonance over sweep frequency.

The sense of the Q control is from GND up with minimum resonance at GND. Oscillation will occur when the current into the Q pin reaches approximately 425 μA. With the input resistor shown this corresponds to +7.5V. The Q control rejection trim is optional and is used to minimize Q control feedthrough which is about -60db when trimmed.

The control summer adds the voltages from various control sources such as the f_c panel control, transient generator, LFO etc. Any number of signals can be summed by applying them through resistors to the summing node of the op amp. The frequency offset adjust is required in polyphonic and programmable systems to make the filter(s) sound the same for an identical input control voltage. For best control rejection, the control summer and input attenuator should be designed so that the maximum swing at the 2044 control pin corresponds to the extremes of the intended sweep range when the control summer is driven to the supplies. With the values shown, one will obtain 180mV at the input pin which corresponds to a 1000:1 sweep range for ±15V supplies. The V/octave trim and the Tel Labs temperature compensating resistor are required in applications where the filter has to produce accurate musical intervals when in oscillation. If this is not necessary the control op amp feedback network and the Tel Labs resistor can be replaced by 1% 300K and 1 K resistors respectively.

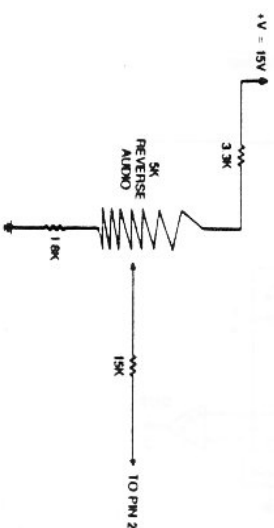

Figure 4